

Leak detection technology

For a clean and protected environment

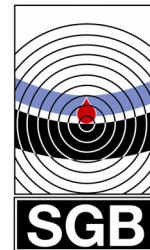

Vacuum leak detector VLX../A-EX and VLX../EX

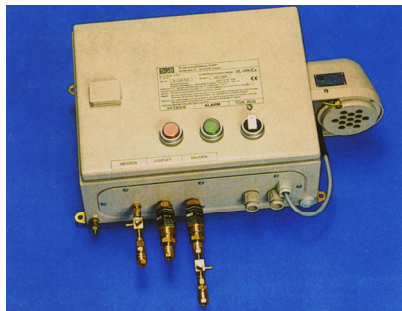

VLX../Ex, complete explosion proof, suitable for installation in zone 1



Leak detector VLX../A-Ex with indicating device VLX/ME. The VLX../A-Ex is suitable for zone 1. The indicating device VLX/ME must be installed outside an potentially explosive area.

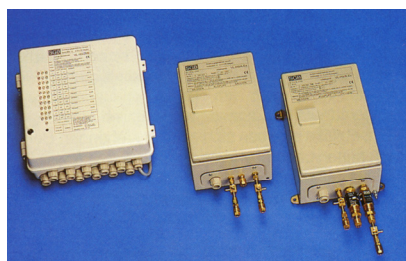

Leak detector VLX../A-Ex with central indicating device VLX/ZME. Up to 10 leak detectors can be connected to the VLX/ZME.

Alarm underpressure in mbar	Operating underpressure in mbar
34 f. VLX 34/A-Ex	ca. 100 mbar
330 f. VLX 330/A-Ex	ca. 500 mbar

Leak detectors in an explosion proof design for monitoring of tanks and pipes with flammable classified liquids.

As all SGB leak detectors the VLX../A-Ex or VLX../Ex monitors permanent both walls of a double walled system and indicates any leak optical and audible before any product can enter the environment.

Several versions of the leak detector VLX../A-Ex and VLX../Ex make a perfect adaptation to local conditions. Because they are small, light and weather protected. No heating is necessary for outdoor installation.

The simple and easy installation is being supported by suitable installation kits. The electrical connection between the leak detector and indicating device is done only with one cable. All electrical and pneumatic construction pieces are equipped with suitable explosion protection.

Three way test valves in measuring and suction line allow for a simple and quick function check of the entire system. Dry relay contacts for alarm transmitting are standard.

The liquid confined parts of the leak detector and the related accessories are available in brass or stainless steel design.

The leak detector VLX../A-Ex and VL../Ex fulfil all requirements regarding explosion protection and gives the highest environmental protection level in accordance to class I of the European standard on leak detection EN 13160.

For the monitoring of:

- double walled underground or aboveground tanks, for example DIN 6608, 6616, 6623, 6618/2
- single walled tank equipped with a lining
- double bottoms of flat bottom aboveground storage tanks
- and others, as long as the use together with the VLX../A-Ex and VLX../Ex is acceptable.
- double walled pipes

Liquids to be monitored:

Water polluting liquids:

hazardous vapours of the liquids must be classified in gas group II A or II B and temperature code T 1 up to T 3

e.g.: gasoline/petrol, jet fuel, diesel, chemicals, lye, acid

approvals: Germany: Z - 65.22-340 and Z - 65.25-341

Sold by:

SGB GmbH

Hofstr. 10
Postfach: 21 07 41

D-57076 Siegen
D-57031 Siegen

Tel.: + 49 / (0) 271 / 48964-0
Fax: + 49 / (0) 271 / 48964-6
<http://www.sgb.de>
E-mail: sgb@sgb.de

Leckanzeigetechnik

For a clean and protected environment

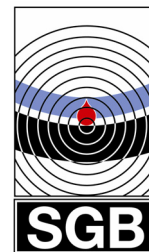

Vacuum leak detector VLX../A-Ex und VLX../EX

Installation examples:

- Measuring line
- Suction line
- Exhaust line
- ⊗ Detonation flame arrester
- ⚠ Liquid stop valve

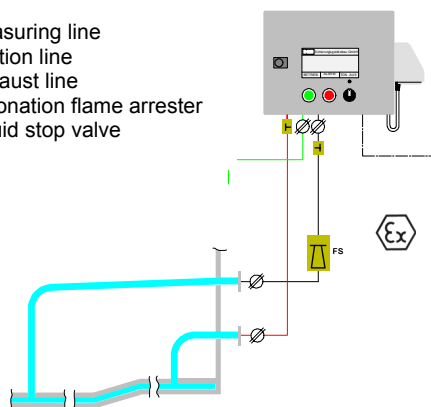

VLX 330/EX on a flat bottom storage tank

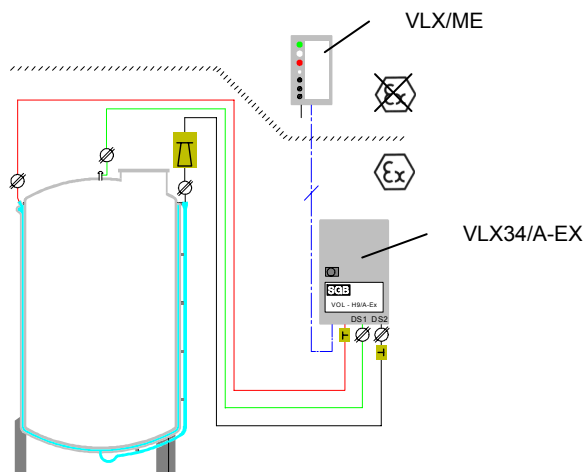

VLX 34/A-EX with VLX/ME on an upright standing cylindrical tank (e.g. DIN 6618/2). A suction line to the lowest point of the interstice is required.

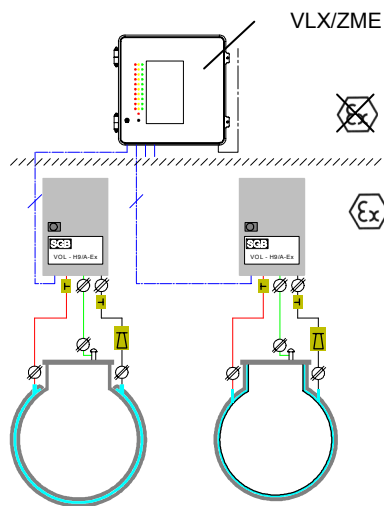

VLX 330/A-EX with VLX/ZME on several underground storage tanks.

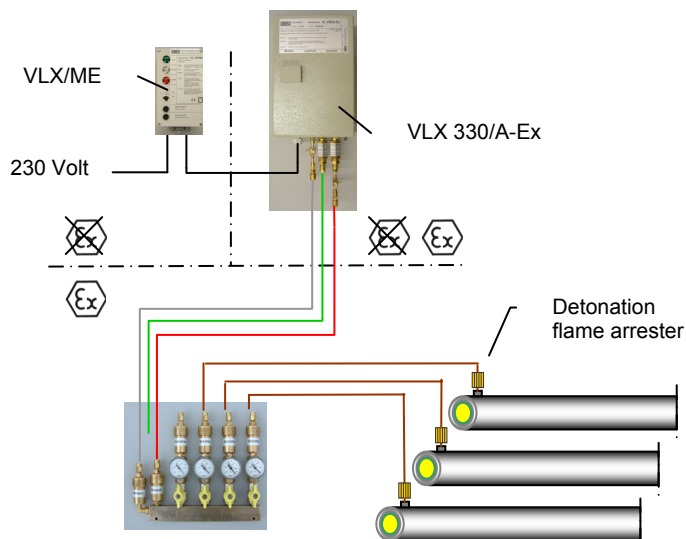

VLX 330/A-EX for monitoring double walled pipes.

All variations of the VLX../A-Ex and VLX../Ex can be used for the different type of tanks. So we recommend for a tank farm the VLX 330/A-Ex with the central indicating unit VLX/ZME. Other variations, which are not shown here, will give the right answer to a wide field of applications. Installation, starting up and maintenance shall be done by a qualified person in accordance to the documentation and the approval.

Subject to changes. Photos and Dimensions are not binding for the extend of delivery.

SGB GmbH
Hofstr. 10
Postfach: 21 07 41

D-57076 Siegen
D-57031 Siegen

Tel.: + 49/(0) 271 / 48964-0
Fax: + 49/(0) 271 / 48964-6
<http://www.sgb.de>
E-mail: sgb@sgb.de